

Features

- Available in E12 series
- Inductance range: 1.0 μ H to 47 mH
- RoHS compliant*

Applications

- Power supplies
- DC/DC converters
- General use

RLB9012 Radial Inductor

General Specifications

Inductance Drop at Rated Current (IDC)	5 %
Operating Temperature	-55 °C to +105 °C
Storage Temperature	-40 °C to +105 °C

Materials

Core Material	Ferrite DR core
Wire	Enameled copper wire
Terminal	Cu/AG/Sn
Tube	Shrinkable tube 125 °C, 600 V

Product Dimensions

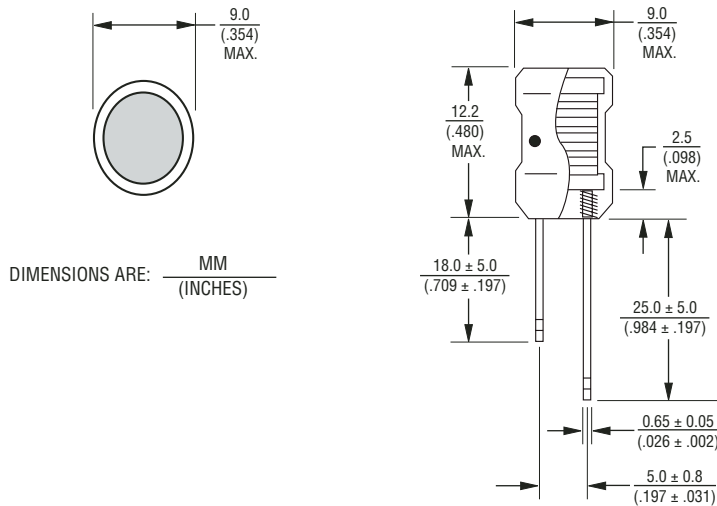

Electrical Schematic

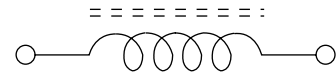

Typical Part Marking



Inductance Code:
 - First two digits are significant
 - Third digit represents the number of zeroes to follow

• = Start

Electrical Characteristics

BOURNS Part No.	Inductance (μ H)	Q ref.	Test freq. (MHz)		SRF (MHz) min.	RDC (ohms) max.	IDC (A) max.
			L	Q			
RLB9012-1R0ML	1.0 \pm 20 %	20	1K	7.96	150.00	0.013	10.0
RLB9012-1R5ML	1.5 \pm 20 %	20	1K	7.96	100.00	0.016	8.50
RLB9012-2R2ML	2.2 \pm 20 %	20	1K	7.96	90.00	0.021	6.50
RLB9012-3R3ML	3.3 \pm 20 %	20	1K	7.96	65.00	0.025	5.50
RLB9012-4R7ML	4.7 \pm 20 %	20	1K	7.96	51.00	0.030	4.60
RLB9012-6R8ML	6.8 \pm 20 %	20	1K	7.96	29.00	0.035	4.10
RLB9012-100KL	10.0 \pm 10 %	50	1K	2.52	14.00	0.045	3.40
RLB9012-120KL	12.0 \pm 10 %	50	1K	2.52	13.00	0.050	3.10
RLB9012-150KL	15.0 \pm 10 %	50	1K	2.52	12.00	0.056	2.90
RLB9012-180KL	18.0 \pm 10 %	40	1K	2.52	11.00	0.061	2.66
RLB9012-220KL	22.0 \pm 10 %	40	1K	2.52	9.20	0.070	2.40
RLB9012-270KL	27.0 \pm 10 %	40	1K	2.52	8.50	0.080	2.22
RLB9012-330KL	33.0 \pm 10 %	30	1K	2.52	7.80	0.090	2.05
RLB9012-390KL	39.0 \pm 10 %	30	1K	2.52	6.90	0.100	1.85
RLB9012-470KL	47.0 \pm 10 %	30	1K	2.52	6.50	0.160	1.77
RLB9012-560KL	56.0 \pm 10 %	30	1K	2.52	5.40	0.180	1.48

Packaging: 200 pieces per bag; available 500 pieces per tape and reel (13-inch reel) by ordering P/N RLH9012-xxxML or -xxxKL.

*RoHS Directive 2002/95/EC Jan 27 2003 including Annex
 Specifications are subject to change without notice.
 Customers should verify actual device performance in their specific applications.

RLB9012 Radial Inductor

Electrical Characteristics (Continued)

BOURNS Part No.	Inductance (μ H)	Q ref.	Test freq. (MHz)		SRF (MHz) min.	RDC (ohms) max.	IDC (A) max.
			L	Q			
RLB9012-680KL	68.0 \pm 10 %	30	1K	2.52	4.90	0.210	1.36
RLB9012-820KL	82.0 \pm 10 %	30	1K	2.52	4.10	0.230	1.30
RLB9012-101KL	100.0 \pm 10 %	20	1K	0.796	3.70	0.280	1.40
RLB9012-121KL	120.0 \pm 10 %	20	1K	0.796	3.40	0.320	1.25
RLB9012-151KL	150.0 \pm 10 %	20	1K	0.796	3.20	0.370	1.15
RLB9012-181KL	180.0 \pm 10 %	20	1K	0.796	2.80	0.580	1.08
RLB9012-221KL	220.0 \pm 10 %	20	1K	0.796	2.70	0.650	1.00
RLB9012-271KL	270.0 \pm 10 %	20	1K	0.796	2.40	0.750	0.90
RLB9012-331KL	330.0 \pm 10 %	20	1K	0.796	2.30	0.850	0.78
RLB9012-391KL	390.0 \pm 10 %	20	1K	0.796	2.10	1.000	0.74
RLB9012-471KL	470.0 \pm 10 %	20	1K	0.796	1.90	1.100	0.68
RLB9012-561KL	560.0 \pm 10 %	20	1K	0.796	1.80	1.400	0.64
RLB9012-681KL	680.0 \pm 10 %	20	1K	0.796	1.60	1.600	0.59
RLB9012-821KL	820.0 \pm 10 %	20	1K	0.796	1.50	1.800	0.56
RLB9012-102KL	1000.0 \pm 10 %	20	1K	0.252	1.30	2.900	0.51
RLB9012-122KL	1200.0 \pm 10 %	15	1K	0.252	1.20	3.400	0.48
RLB9012-152KL	1500.0 \pm 10 %	15	1K	0.252	1.10	3.800	0.43
RLB9012-182KL	1800.0 \pm 10 %	15	1K	0.252	1.00	5.300	0.39
RLB9012-222KL	2200.0 \pm 10 %	15	1K	0.252	0.80	5.900	0.36
RLB9012-272KL	2700.0 \pm 10 %	15	1K	0.252	0.70	8.200	0.32
RLB9012-332KL	3300.0 \pm 10 %	15	1K	0.252	0.60	9.100	0.29
RLB9012-392KL	3900.0 \pm 10 %	15	1K	0.252	0.55	9.900	0.27
RLB9012-472KL	4700.0 \pm 10 %	15	1K	0.252	0.50	13.60	0.24
RLB9012-562KL	5600.0 \pm 10 %	15	1K	0.252	0.45	14.90	0.22
RLB9012-682KL	6800.0 \pm 10 %	15	1K	0.252	0.40	20.70	0.20
RLB9012-822KL	8200.0 \pm 10 %	15	1K	0.252	0.35	22.70	0.18
RLB9012-103KL	10,000 \pm 10 %	15	1K	0.079	0.32	25.10	0.17
RLB9012-123KL	12,000 \pm 10 %	15	1K	0.079	0.28	34.70	0.15
RLB9012-153KL	15,000 \pm 10 %	15	1K	0.079	0.25	48.90	0.14
RLB9012-183KL	18,000 \pm 10 %	15	1K	0.079	0.23	53.60	0.12
RLB9012-103KL	10,000 \pm 10 %	15	1K	0.079	0.32	25.10	0.17
RLB9012-123KL	12,000 \pm 10 %	15	1K	0.079	0.28	34.70	0.15
RLB9012-153KL	15,000 \pm 10 %	15	1K	0.079	0.25	48.90	0.14
RLB9012-183KL	18,000 \pm 10 %	15	1K	0.079	0.23	53.60	0.12
RLB9012-223KL	22,000 \pm 10 %	15	1K	0.079	0.21	59.30	0.11
RLB9012-273KL	27,000 \pm 10 %	15	1K	0.079	0.19	82.70	0.10
RLB9012-323KL	33,000 \pm 10 %	15	1K	0.079	0.17	91.50	0.09
RLB9012-393KL	39,000 \pm 10 %	15	1K	0.079	0.15	125.50	0.08
RLB9012-473KL	47,000 \pm 10 %	15	1K	0.079	0.12	137.80	0.08

Packaging: 200 pieces per bag; available 500 pieces per tape and reel (13-inch reel) by ordering P/N RLH9012-xxxML or -xxxKL.



Asia-Pacific: TEL +886- (0)2 25624117 • FAX +886- (0)2 25624116
Europe: TEL +41-41 768 5555 • FAX +41-41 768 5510
The Americas: TEL +1-951 781-5500 • FAX +1-951 781-5700
www.bourns.com

REV. 11/08

Specifications are subject to change without notice. Customers should verify actual device performance in their specific applications.